

TOTEM Roman Pot Motherboard RPMB

Specification

Version 2

G. Antchev – Last update: November 7, 2008

*This document is specification of the TOTEM Roman Pot Motherboard "RPMB"
The differences from the previous version are with **red** in the text*

Table of Contents

1. Introduction.....	3
2. Block Diagram	3
3. Components	4
3.1. Mezzanine Cards.....	6
3.1.1. Trigger VFAT Mezzanine	6
3.1.2. Coincidence Chip Mezzanine	7
3.1.3. CCUM and GOH Mezzanines	7
4. Control Interface	8
4.1. I2C Devices.....	9
5. Data Output Interface	11
5.1. Block Structure	11
5.2. Data Format.....	11
6. Trigger Output Interface	11
6.1. Block Structure	11
6.2. Trigger Bits.....	11
7. Slow Control	11
7.1. RADMON Carrier.....	12
7.2. Temperature Sensors	12
8. Power	12
9. References	12

List of Figures

Figure 1 RPMB Block Diagram	3
Figure 2 RPMB Photo – Top and Bottom side	5
Figure 3 Trigger VFAT mezzanine	6
Figure 4 Zoom on Trigger Outputs	6
Figure 5 CC Mezzanine.....	7
Figure 6 CCUM Mezzanine.....	7
Figure 7 RADMON Carrier	12

List of Tables

Table 1 I2C Channels and Devices	10
Table 2 CCUM Parallel Port Bits Assignments.....	10
Table 3 Control of GOH's Power Up sequence.....	11

1. Introduction

The TOTEM experiment has three sub-detectors: Roman Pots (RP) with silicon strips, T1 detector with Cathode Strip Chambers (CSC) and T2 with Gas Electron Multiplier detectors (GEM). All detectors use the VFAT chip for tracking and trigger generation mounted on different hybrids. A Roman Pot hybrid contains four VFAT chips. The set of ten hybrids is build for every Roman Pot.

The RPMB is connecting to this set via flex connections and glued to the flange. This document will give a detailed specification of the design and functionality of the RPMB, and its components as a part of the front-end electronics in Roman Pot for TOTEM experiment.

2. Block Diagram

The block diagram of the board with its connectivity to the hybrids is shown on Figure 1:

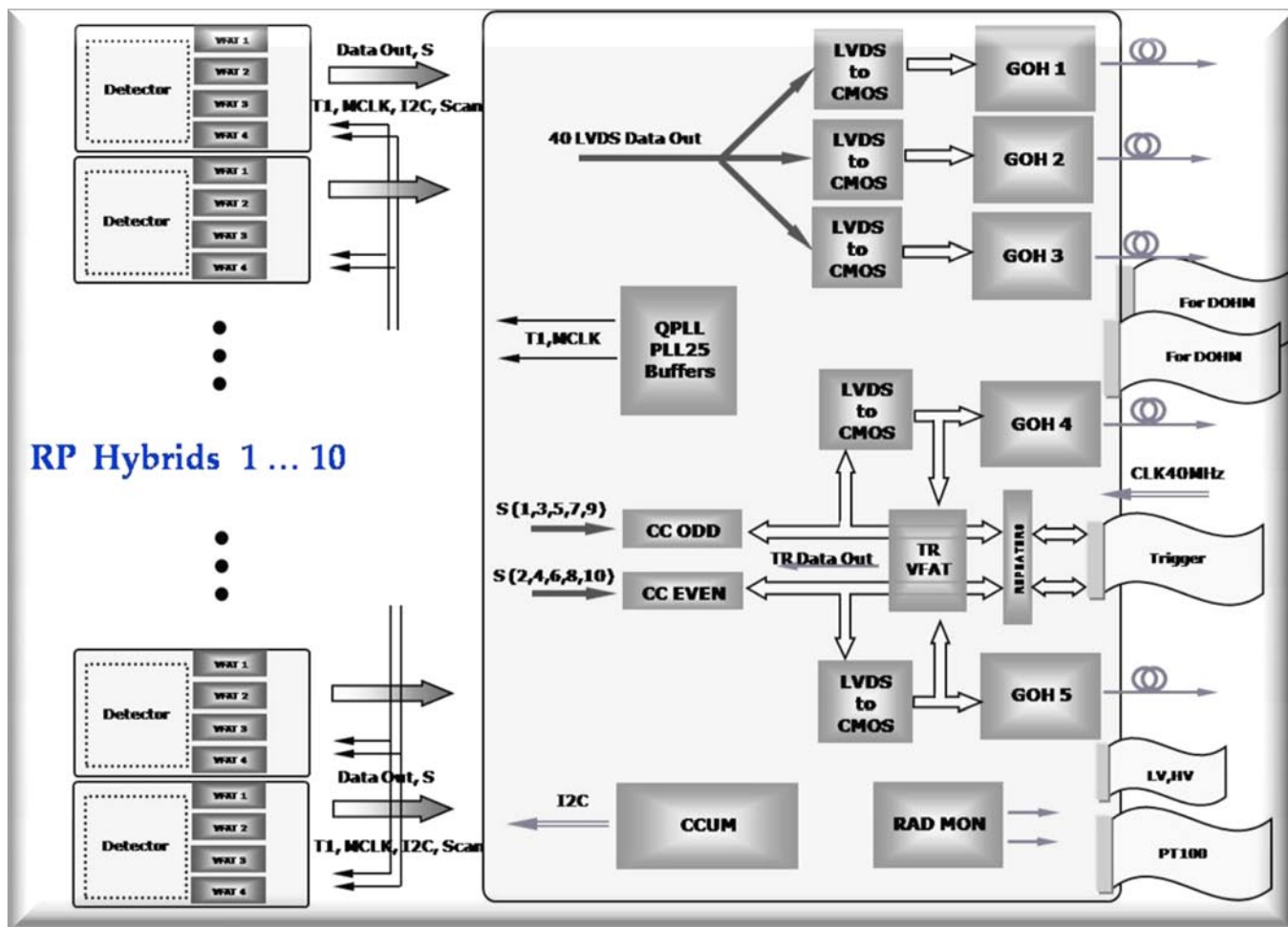

Figure 1 RPMB Block Diagram

3. Components

The design of the board is done in the way to able to mount it on top of the Roman Pot. From one side it is connected to the RP Hybrids and from the other via front panel to the counting room. The board accepts several number of mezzanines card which will be described later in this document. A front panel with connectors for low and high voltage, control, data and trigger bits transfer is used to facilitate the connection to the central patch panel of the RP stations.

The "RPMB" contains the following general building blocks:

- Control Logic Block – is based on CERN common used Communication and Control Unit CCUM mezzanine. This module is connected to the control loop (DOHM and FEC-CCS) via two 20pins 3M high speed connectors placed on the front panel. Control logic block provides 16 I²C interface channels and one 8 bit parallel control port;
- Clock and Commands Distribution Block – is based on PLL25 chip, QPLL and number of clock and commands distribution circuitry to deliver synchronous clock and commands to every component on the board including the VFAT chips on the RP Hybrids;
- Data Conversion and Transmission Block – is based on LVDS to CMOS converters and gigabit optical hybrids GOH modules. Three GOH modules are used to send data from 40 VTAF chips to the counting room;
- Trigger Transmission Block – is based on Coincidence chip mezzanine, LVDS to CMOS converters, Trigger VFAT mezzanine and two GOH modules. To transmit trigger bits to the counting room two ways have been selected: optical fibers are used for the 150m RP station and in TOTEM standalone runs also for the 220m station. The runs with CMS on the other hand are subject to CMS's limited trigger latency time, imposing trigger bit transmission with LVDS signals through fast electrical cables. The electrical transmission over such a long distance requires care to preserve signal integrity. This can only be achieved by restoring the LVDS signals to full levels at regular intervals over the transmission distance. A special integrated circuit was designed for this purpose: the LVDS repeater chip can treat 16 LVDS channels in parallel and was designed in special layout to guarantee radiation tolerance. This chip will be mounted on a small repeater board. At regular intervals of about 70m a repeater station is introduced which consists of several repeater boards with cable connectors;
- Slow Control Block – includes digital/analog LV and HV power distribution, temperature, pressure and radiation monitoring. For measuring the temperature on the hybrids and inside in the pot the PT100/1000 sensors are using. Special RADMON small mezzanine card is using for radiation monitoring on the board.

TOTEM Roman Pot Motherboard

The RPMB is 16 layers double-side printed circuits board halogen-free material. The location in the experiment means that board will be exposed to different levels of radiation. That is why components on the board are specially designed by CERN microelectronics group using radiation hardness technology. Photo of the board top and bottom side without mezzanines is shown on Figure 2:

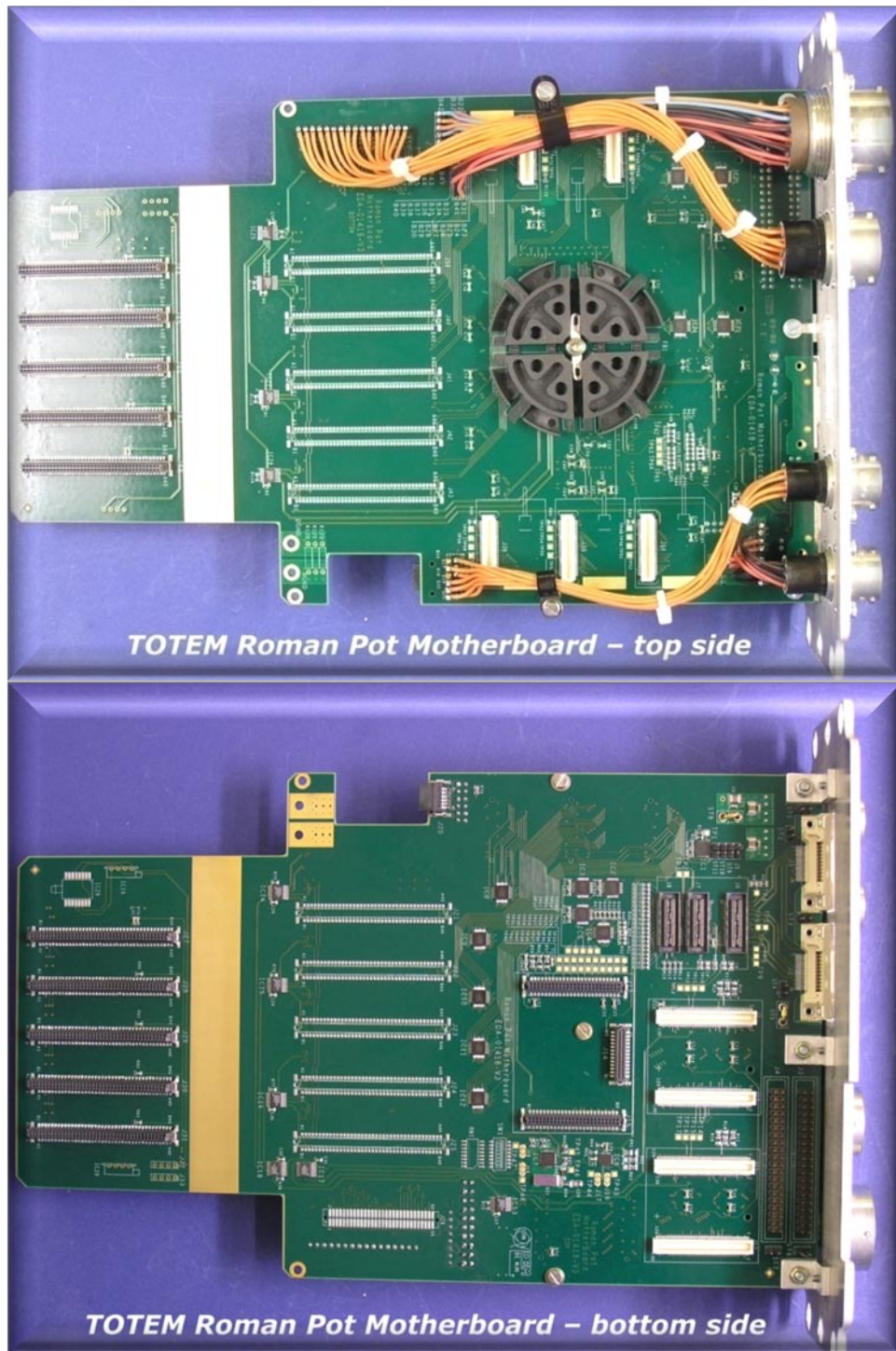

Figure 2 RPMB Photo – Top and Bottom side

TOTEM Roman Pot Motherboard

3.1. Mezzanine Cards

On the motherboard the following mezzanines can be implemented: Trigger VFAT, Coincidence Chip, CCUM, GOH and RADMON.

3.1.1. Trigger VFAT Mezzanine

Trigger VFAT mezzanine is using to generate control signal from its BCO test output and to serialize trigger bits from the VFAT's and send them via GOH optically to the counting room. The BCO test output is using to synchronize trigger bits on trigger GOH's. This synchronization is done by disabling the GOH's data valid signal for duration of one clock cycle. The photo of the mezzanine is shown on Figure 3 and the zoom on trigger outputs scheme from RPMB block diagram is on Figure 4.



Figure 3 Trigger VFAT mezzanine

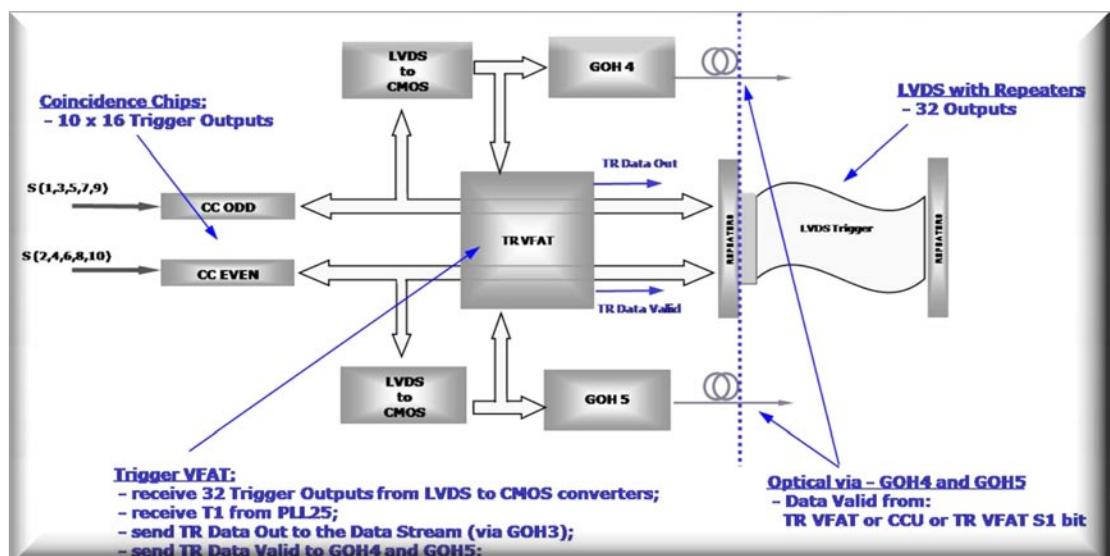

Figure 4 Zoom on Trigger Outputs

3.1.2. Coincidence Chip Mezzanine

The VFAT's are generating fast signals which are used to provide the trigger signals provided by TOTEM to the CMS global trigger box. A full custom chip rather than using a Field Programmable Gate Array was developed for two main reasons:

1. The latency constraints on the generation of the trigger bits especially from the Roman Pots are very severe: after subtraction of cable delays only about 8-10 bunch crossings are left for the generation of the trigger signals to be provided to CMS from the signals generated by the Roman Pot detector front end. A full custom chip with dedicated logic can implement the required coincidence in one clock.
2. Special design techniques can make a full custom chip much more robust against radiation both with regard to total dose and single event effects. This allows placing this chip in aggressive radiation environments very near the detectors.

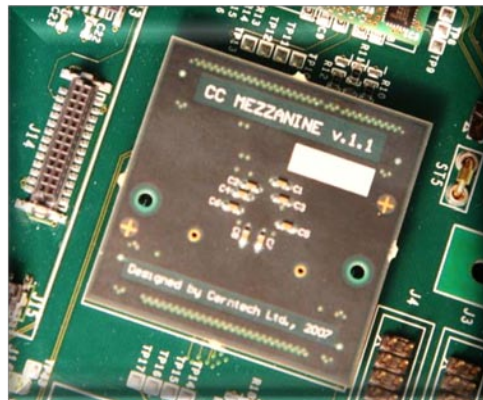

Figure 5 CC Mezzanine

The special mezzanine was designed with one Coincidence Chip and two 130pins input/output connectors.

3.1.3. CCUM and GOH Mezzanines

The CCUM and GOH mezzanines

TBD



Figure 6 CCUM Mezzanine

4. Control Interface

The control interface on the board is based on CCUM mezzanine and TOTEM Digital Opto-Hybrid Module DOHM. The TOTEM DOHM module is the same as CMS Tracker DOHM with different input/output connectors to RPMB. The CCUM mezzanine provides up to 16 I2C channels. On every channel different number of I2C devices are connected.

4.1. I2C Devices

The following Table 1 shows all devices per I2C channel with their names and addresses:

RPMB I2C Devices			
Channel N:	Channel Address [HEX] -> Name	I2C Address [HEX]	Device Name
0	0x10 -> CCUM	0x00	CCU25
1	0x11 -> PLANE1	0x10	VFAT1
		0x20	VFAT2
		0x30	VFAT3
		0x40	VFAT4
		0x50	DCU
2	0x12 -> PLANE2	0x10	VFAT1
		0x20	VFAT2
		0x30	VFAT3
		0x40	VFAT4
		0x50	DCU
3	0x13 -> PLANE3	0x10	VFAT1
		0x20	VFAT2
		0x30	VFAT3
		0x40	VFAT4
		0x50	DCU
4	0x14 -> PLANE4	0x10	VFAT1
		0x20	VFAT2
		0x30	VFAT3
		0x40	VFAT4
		0x50	DCU
5	0x15 -> PLANE5	0x10	VFAT1
		0x20	VFAT2
		0x30	VFAT3
		0x40	VFAT4
		0x50	DCU
7	0x17 -> PLANE7	0x10	VFAT1
		0x20	VFAT2
		0x30	VFAT3
		0x40	VFAT4
		0x50	DCU
8	0x18 -> PLANE8	0x10	VFAT1
		0x20	VFAT2
		0x30	VFAT3
		0x40	VFAT4
		0x50	DCU

9	0x19 -> PLANE9	0x10	VFAT1
		0x20	VFAT2
		0x30	VFAT3
		0x40	VFAT4
		0x50	DCU
10	0x1A -> PLANE10	0x10	VFAT1
		0x20	VFAT2
		0x30	VFAT3
		0x40	VFAT4
		0x50	DCU
11	0x1B -> DATA	0x10	GOH1
		0x20	GOH2
		0x30	GOH3
		0x40	GOH4
		0x50	GOH5
12	0x1C -> CLOCK/TRIGGER	0x10	PLL25
		0x20	TR_VFAT
		0x30	CC_ODD
		0x40	CC_EVN
13	0x1D -> CNTRL/DOHM 1	0x70	DOH - A
14	0x1E -> CNTRL/DOHM 2	0x70	DOH - B
16	0x1F -> SPARE	-	Not Used

Table 1 I2C Channels and Devices

The I2C devices are described in details (registers configuration and programming) in the reference documents.

In order to provide additional control on the board apart from I2C interfaces the parallel port of the CCUM is using. The eight bits has the following assignments, see Table 2:

CCUM Parallel Port Bits			
Bit N:	Name	RPMB Signal	Action
0	BPP1	RES-B	Reset Soft to VFAT's, CC, TR_VFAT
1	BPP2	REH-B	Reset Hard to VFAT's, CC, TR_VFAT
2	BPP3	GOH_FLAG1	Controls GOH's power-up
3	BPP4	GOH_FLAG0	Controls GOH's power-up
4	BPP5	SEL1	Select P1 or P9 DVALID
5	BPP6	SEL2	Select P2 or P10 DVALID
6	BPP7	SEL3	Select (P1 or P9) or (P2 or P10) DVALID
7	BPP8	SEL4	Select TR_BC0 output

Table 2 CCUM Parallel Port Bits Assignments

GOH's Power Up Sequence		
N:	RPMB Signals	Action
1	GOH_FLAG1 and GOH_FLAG0	Write "11" to BPP3 and BPP4 => 0x0C
2	GOH_FLAG1 and GOH_FLAG0	Write "01" to BPP3 and BPP4 => 0x08
3	RESETOUTZ	Reset CCUM (* if OptoRX is not in synch)

Table 3 Control of GOH's Power Up sequence

5. Data Output Interface

5.1. Block Structure

The data output interface is build using the data conversion and transmission block. Four serial data outputs from every plane in LVDS signal levels format are converting to CMOS level using CRT910 chips. Then 40 data bits are entering three GOH's 16bit each, to be serialized and send to the counting room. For synchronization of the data stream programmable data valid (DVALID) signal from the VFAT's is using to enable the GOH hybrids.

5.2. Data Format

The data format is defined by the VFATs and it is presented on Figure 7.

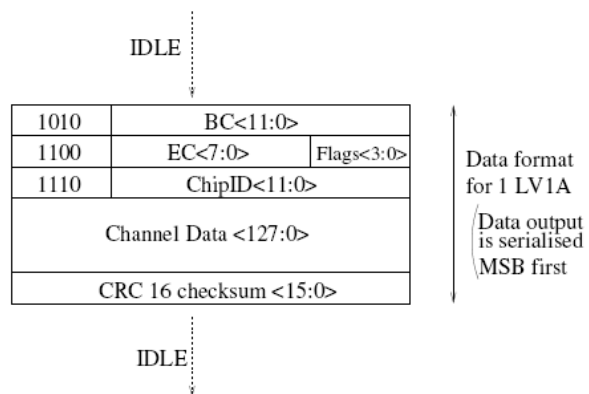

Figure 7 VFAT data format for one trigger

6. Trigger Output Interface

6.1. Block Structure

6.2. Trigger Bits

7. Slow Control

8.

8.1. RADMON Carrier

The RADMON carrier is made of a thin (~500 μ m) double-sided PCB. It can host up to 5 $p-i-n$ diodes and can allow the readout of five RadFETs mounted inside a proper package. A total of 11 devices, including a temperature sensor (10k NTC), can be mounted on the integrated sensor PCB and readout via a 12-way flat cable: 11 for sensor signals and a common Return Line (RL) connection.

The on-board connector is an ERNI Male SMC-B 12 contacts (model 054594). The overall dimensions of the assembled PCB, including the connector plug, are of about 34 mm \times 15 mm \times 4 mm. See more details in [8].

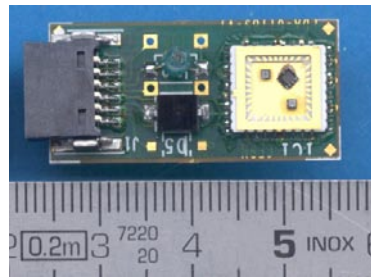

Figure 8 RADMON Carrier

8.2. Temperature Sensors

9. Power

10. References

1. CCU25 - [Communication and Control Unit](#)
2. VFAT - [VFAT2 - Logical functionality \(Version 9\)](#) (also for TR_VFAT)
3. DCU - [DCU2 User Guide](#)
4. CC - [Coincidence Chip Specification](#) (for CC_ODD, CC_EVN)
5. PLL25 - [CMS Tracker PLL Reference Manual](#)
6. DOH - [Front-end Digital Opto-Hybrid](#)
7. GOH - [GOL Reference Manual](#)
8. RADMON - [TOTEM on-line Radiation Monitoring System](#)